

DECOUPE JET D'EAU



BYSTRONIC ByJet Smart 1350

Table (mm)

3000 * 1500

Découpe

Acier
Titane
Verre

Épaisseur (mm)

150
100
50

TOURNAGE

CAZENEUVE 360 HBX
HARRISON M400
HARRISSON V350
PADOVANI 255
PADOVANI Labor 255
PADOVANI E275
PINACHO Mustang 200
STANKO 16 K 20
TOS SN 400S
TRAUB TNA 300
TUR 560

\varnothing_{br}	\varnothing_m	\varnothing_n	\varnothing_b	\varnothing_c	\varnothing_t	Le
55	120	180	360	190	280	500
65	150	300	430	300	320	1600
42	140	230	400	165	400	650
100	100	360	540	320	450	2000
70	150	310	520	320	510	1500
100	100	360	560	360	440	2000
60	150	310	420	230	440	1000
55	110	280	400	200	480	1000
75	160	240	400	220	480	950
64	105	214	/	/	350	600
100	210	384	560	315	540	2000

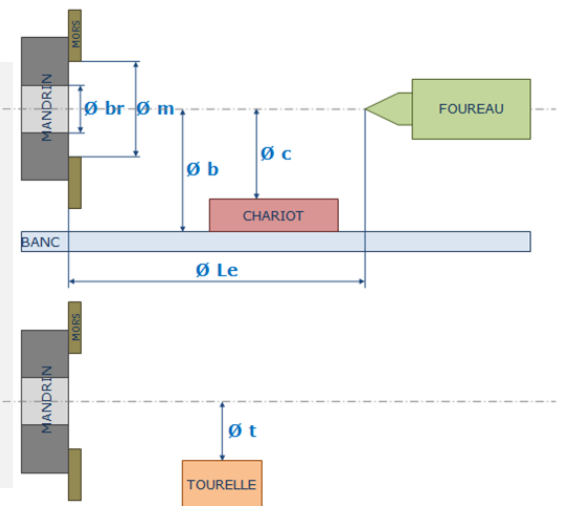

FRAISAGE



BROTHER TC 22-A
CINCINNATI Arrow 1250 C
CINCINNATI Sabre 1000
CORREA CF 22-20
CORREA CF 22-25
DUFOUR LS 303 C
FANUC Robodrill α - T21iFa
KIHEUNG KNC U800
LAGUN FTV2
LAGUN 1600
MAHO MH 500 W3
MIKRON WF 51D
QUICKJET R2-A

Table (mm)

640	*	400
1370	*	600
1120	*	510
2000	*	700
2530	*	700
1150	*	300
650	*	400
2000	*	825
1219	*	228
1600	*	800
800	*	360
1000	*	500
950	*	400

Course (mm)

500	*	400	*	410
1270	*	510	*	560
1020	*	510	*	560
2000	*	800	*	800
2500	*	800	*	800
750	*	295	*	390
500	*	400	*	330
1600	*	800	*	800
1200	*	470	*	600
1430	*	940	*	1000
500	*	380	*	350
710	*	500	*	460
700	*	400	*	320

SCIAGE

	<u>Épaisseur max. (mm)</u>
STRIEBIG Standard 6220 A/G	20
RAPID Mad 800	120
ALTENDORF F45	120
ALTENDORF F90	120
CASADEI KS 3400 b	350
MEBER DS 500/600	350
UZAY Umso 330	Ø 330



RABOTAGE



	<u>l * h (mm)</u>	
CASADEI PS 63	630	* 300
SICAR FORTE 630	600	* 300

PERCAGE

	<u>Table (mm)</u>		<u>Course (mm)</u>	
ERLO TC 25	420	* 400	1100	* 180
FELISATI 340	400	* 400	800	* 150
FMO RF 401 VC	590	* 200	650	* 150



CHAUDRONNERIE



Défonceuse CASADEI MK/1
 Toupie CASADEI F114
 Plieuse BOMBLED 351 E
 Plieuse à chaud HP BURGER HBR 200
 Soudeuse ROWELD P 160 Saniline
 Soudeuse WEGNER SV 300
 Presse SAHINDER DP 1040660 TON
 Étuve ECCE

MOYENS DE CONTRÔLE

Marbre 1200*800 mm
 Colonne de mesure capacité 600 mm
 Appareil électronique de mesure de la rugosité
 Duromètre
 Projecteur de profil
 (+ Moyens conventionnels)



MANUTENTION

Chariot élévateur
 Transpalettes

INFORMATIQUE

Poste CAO TOP SOLID
 Poste CFAO 3D surfacique TOP CAM (tournage, fraisage)